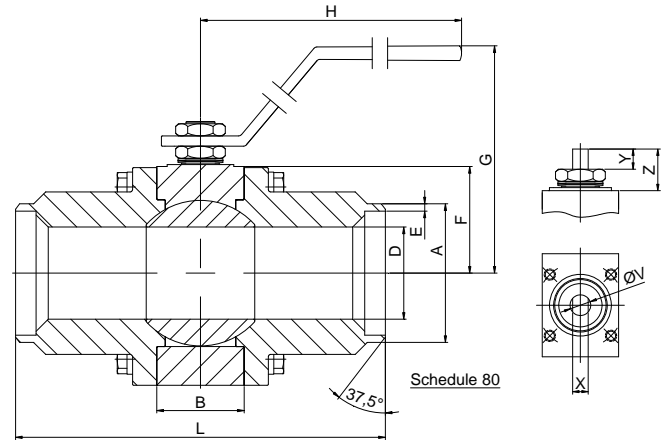
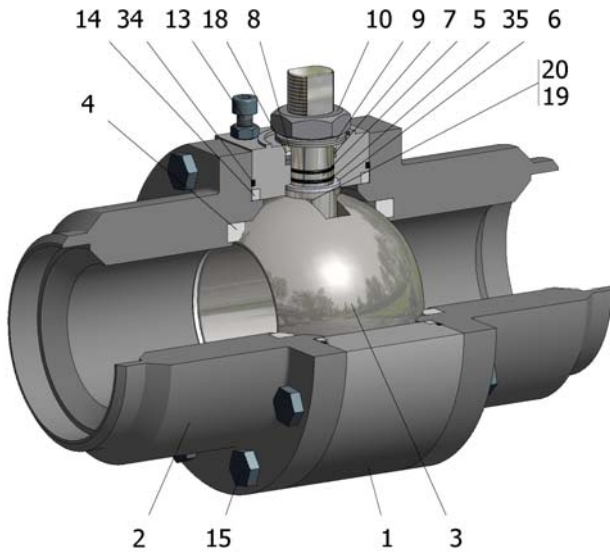

FIG.KRB 806 SGSGV CL400 4" BW



Position	Description	Material
01	Body 1	A182 F316/316L
02	Body 2	A182 F316/316L
03	Ball	A182 F316/316L
04	Seat	PTFE+CG
05	Stem	S.S. AISI 316/316L
06	Stem seal	PTFE+CG
07	Stem packing 1	Graphite
08	Gland packing	S.S. AISI 316
09	Spring washer	S.S. AISI 301
10	Stem nut	S.S. AISI 304
13	Stop bolt	S.S. (316)
14	Body seal 1	PTFE+CG
15	Body bolt	A193 B8M
16	Handle	PAINTED C.S.
18	Thrust washer	PTFE+CG
19	Spring	S.S. AISI 316
20	Antistatic ball	S.S. AISI 316
34	Body seal 2	Graphite
35	O ring stem	FKM

General features

Three pieces.
 Reduced bore.
 Soft seat.
 Bidirectional.
 Anti Blow out proof stem.
 Autoadjustable packing.
 Anti static device.
 Self-cavity pressure relief.

Standards

Top flange ISO 5211
 Buttwelding ends B16.25
 Materials according to NACE MR0175
 Design B16.34
 Testing API 598, BS 6755-1

Official approvals

CERTIFICATE FIRE SAFE
 ATEX 2014/34/EU
 PED 2014/68/EU
 SIL 3 CAPABLE

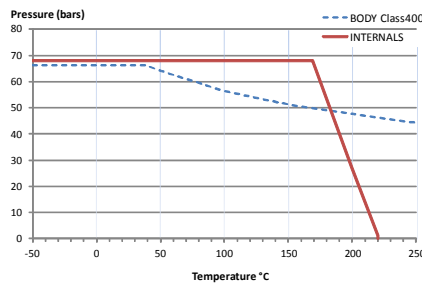

PEKOS GROUP CERTIFICATES:



DIMENSIONS & Technical information

DN	CL	D	L	E	A	B	C	F	H	G	V	X	Y	Z	n x d	ISO 5211	Torque	MAST	Weight
4"	400	76	305	8,56	114,3	72	-	88	425	170	24	18	20	37	- x -	F07	120	310,3	16,0

** Depending on service conditions.

* Dimensions are in mm.

* Torque & MAST are in Nm

* Weight is in Kilogram

* Torque values have been measured ΔP at maximum rating at room temperature

DS-430
Rev.7