

## FIG.K 809 SGSGV CL400 3" NPT

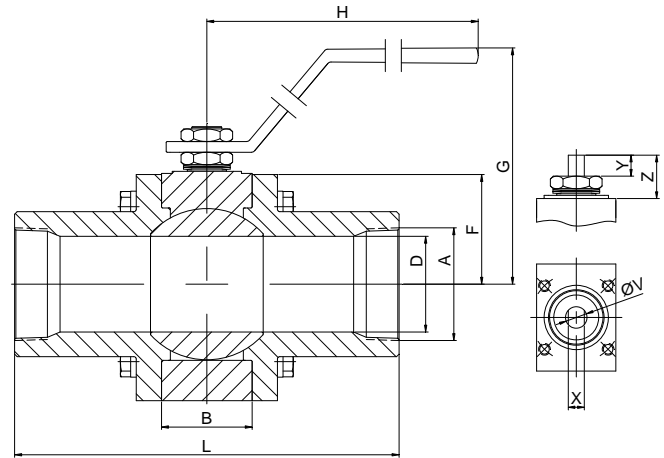
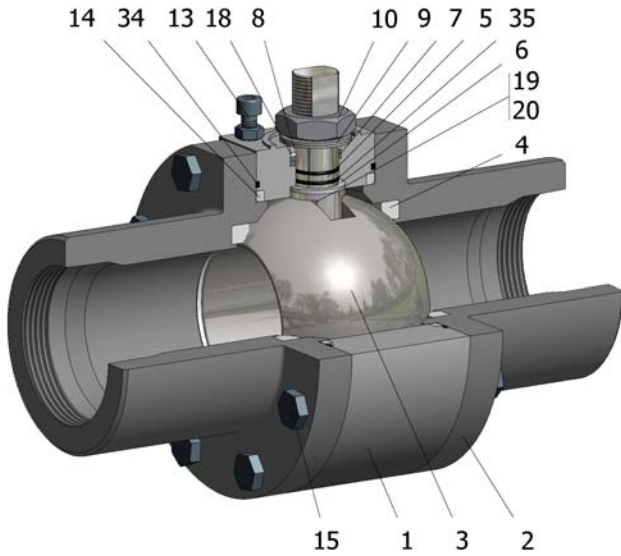

Position	Description	Material
01	Body 1	C.S. A350 LF2/A-105
02	Body 2	C.S. A350 LF2/A-105
03	Ball	A182 F316/316L
04	Seat	PTFE+CG
05	Stem	S.S. AISI 316/316L
06	Stem seal	PTFE+CG
07	Stem packing 1	Graphite
08	Gland packing	S.S. AISI 316
09	Spring washer	S.S. AISI 301
10	Stem nut	S.S. AISI 304
13	Stop bolt	S.S. (316)
14	Body seal 1	PTFE+CG
15	Body bolt	A320 L7M
16	Handle	PAINTED C.S.
18	Thrust washer	PTFE+CG
19	Spring	S.S. AISI 316
20	Antistatic ball	S.S. AISI 316
34	Body seal 2	Graphite
35	O ring stem	FKM

### General features

Three pieces.  
 Full bore.  
 Soft seat.  
 Bidirectional.  
 Anti Blow out proof stem.  
 Autoadjustable packing.  
 Anti static device.  
 Self-cavity pressure relief.

### Standards

Top flange ISO 5211  
 Threaded ends NPT  
 Materials according to NACE MR0175  
 Design B16.34  
 Testing API 598, BS 6755-1

### Official approvals

CERTIFICATE FIRE SAFE  
 ATEX 2014/34/EU  
 PED 2014/68/EU  
 SIL 3 CAPABLE

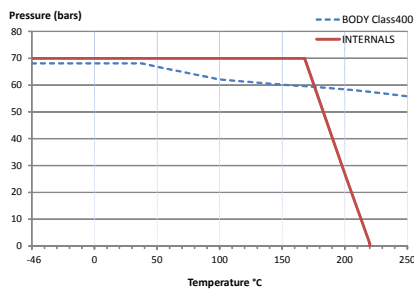

### PEKOS GROUP CERTIFICATES:

ISO 9001-2008 / 2014/68/EU / API-6D



### DIMENSIONS & Technical information

DN	CL	D	L	E	A	B	C	F	H	G	V	X	Y	Z	n x d	ISO 5211	Torque	MAST	Weight
3"	400	76	305	-	3"	72	-	88	425	170	24	18	20	37	- x -	F07	120	310,3	17,5

\*\* Depending on service conditions.

\* Dimensions are in mm.

\* Torque & MAST are in Nm

\* Weight is in Kilogram

\* Torque values have been measured  $\Delta P$  at maximum rating at room temperature

**DS-325**  
 Rev.12