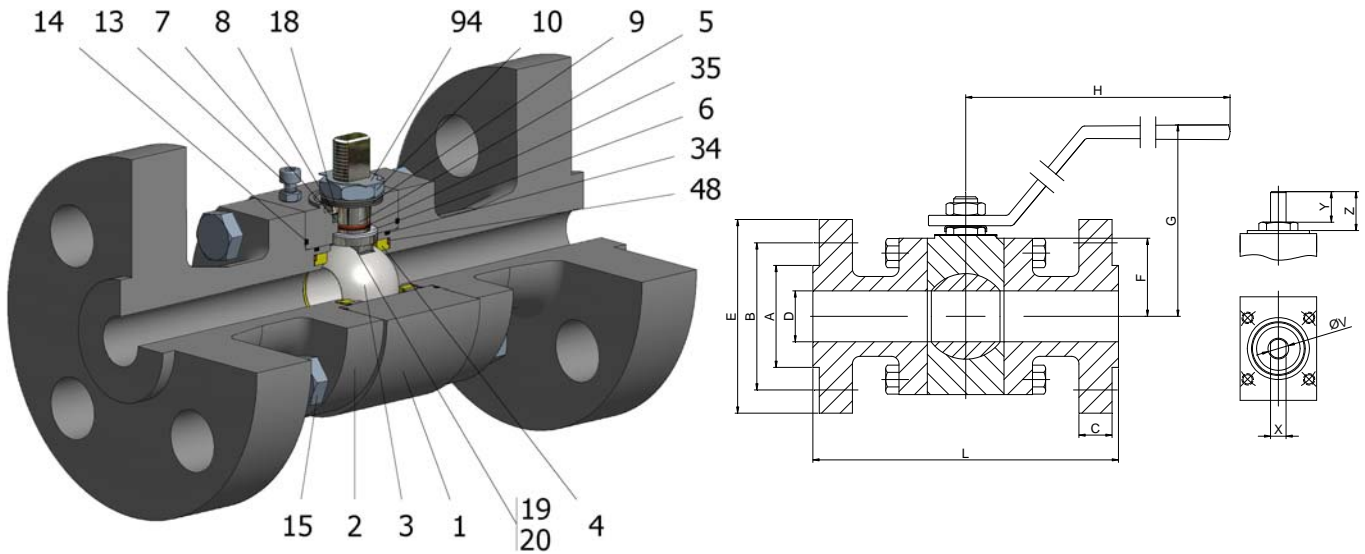

**FIG.K 159 NGGVV CL1500 1/2"-2" RF**



Position	Description	Material
01	Body 1	C.S. A350 LF2/A-105
02	Body 2	C.S. A350 LF2/A-105
03	Ball	S.S. AISI 316
04	Seat	DEVLON V
05	Stem	S.S. AISI 316
06	Stem seal	PEEK
07	Stem packing 1	Graphite
08	Gland packing	S.S. AISI 316
09	Spring washer	S.S. AISI 301
10	Stem nut	S.S. AISI 304
13	Cover bolt	S.S. (316)
14	Body seal 1	Graphite
15	Body bolt	A320 L7M
16	Handle	PAINTED C.S.
18	Thrust washer	PTFE+CG
19	Spring	S.S. AISI 316
20	Antistatic ball	S.S. AISI 316
34	Body seal 2	FKM
35	O ring stem	FKM
48	O ring spring	FKM
94	Stop washer	S.S. AISI 301

**General features**

- Floating ball.
- Three pieces.
- Full bore.
- Soft seat.
- Bidirectional.
- Anti Blow out proof stem.
- Autoadjustable packing.
- Anti static device.
- Self-cavity pressure relief.

**Standards**

- Design B16.34
- Testing API 598, BS 6755-1
- Top flange ISO 5211
- Flanges ANSI B16.5
- Face to face ANSI B16.10
- Materials according to NACE MR0175

**Official approvals**

- CERTIFICATE FIRE SAFE
- ATEX 2014/34/EU
- PED 2014/68/EU
- SIL 3 CAPABLE

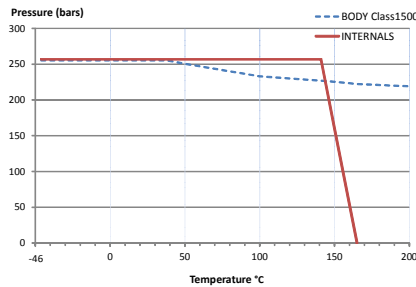

**PEKOS GROUP CERTIFICATES:**

ISO 9001-2008 / 2014/68/EU / API-6D



**DIMENSIONS & Technical information**

DN	CL	D	L	E	A	B	C	F	H	G	V	X	Y	Z	n x d	ISO 5211	Torque	MAST	Weight
1/2"	1500	11,1	216	120	35	83	28	31	180	98	12	7,5	10	14	4 x 22	F03	14	34,1	10,5
3/4"	1500	15,5	229	130	43	89	31	41	180	108	12	7,5	11	12	4 x 22	F04	26	34,1	17,0
1"	1500	21	254	150	51	102	35	46	220	109	15	9	17	21	4 x 25	F05	37	64,7	20,5
1 1/4"	1500	34	279	160	64	111	35	63	250	139	22	16	26	33	4 x 25	F07	120	233,7	22,0
1 1/2"	1500	34	305	180	73	124	38	63	250	139	22	16	26	33	4 x 29	F07	120	233,7	23,0
2"	1500	43	368	215	92	165	44	64	250	140	22	16	20	30	8 x 25	F07	145	233,7	34,0

\*\* Depending on service conditions.

\* Dimensions are in mm.

\* Torque & MAST are in Nm

\* Weight is in Kilogram

\* Torque values have been measured ΔP at maximum rating at room temperature

**DS-2509**  
Rev.7