

## FIG.K 156 NGGVV CL1500 1/4"-2" BW

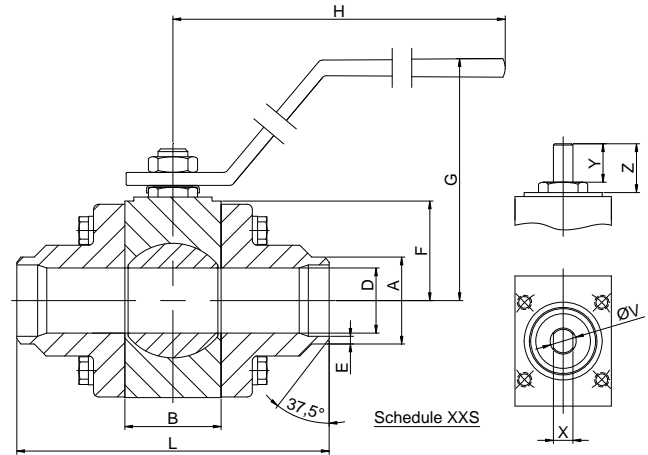
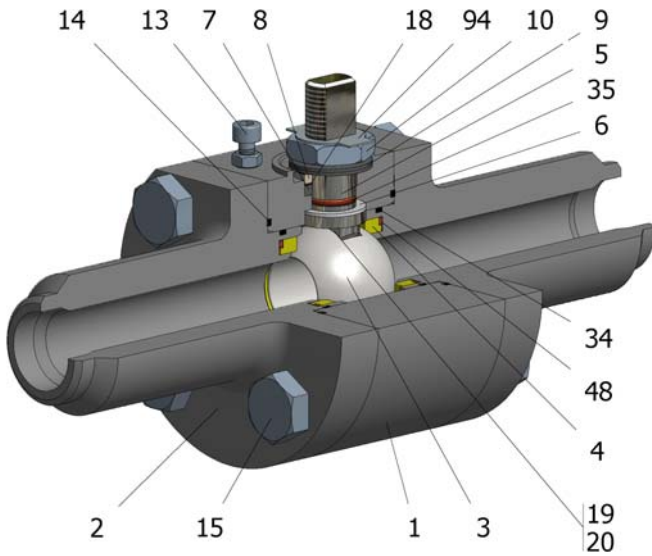

Position	Description	Material
01	Body 1	A182 F316/316L
02	Body 2	A182 F316/316L
03	Ball	A182 F316/316L
04	Seat	DEVLON V
05	Stem	S.S. AISI 316/316L
06	Stem seal	PEEK
07	Stem packing 1	Graphite
08	Gland packing	S.S. AISI 316
09	Spring washer	S.S. AISI 301
10	Stem nut	S.S. AISI 304
13	Cover bolt	S.S. (316)
14	Body seal 1	Graphite
15	Body bolt	A193 B8M
16	Handle	WCB
18	Thrust washer	PTFE+CG
19	Spring	S.S. AISI 316
20	Antistatic ball	S.S. AISI 316
34	Body seal 2	FKM
35	O ring stem	FKM
48	O ring spring	FKM
94	Stop washer	S.S. AISI 304

### General features

Floating ball.  
 Three pieces.  
 Full bore.  
 Soft seat.  
 Bidirectional.  
 Anti Blow out proof stem.  
 Autoadjustable packing.  
 Anti static device.  
 Self-cavity pressure relief.

### Standards

Design B16.34  
 Testing API 598, BS 6755-1  
 Top flange ISO 5211  
 Buttwelding ends B16.25  
 Face to face ANSI B16.10  
 Materials according to NACE  
 MR0175

### Official approvals

CERTIFICATE FIRE SAFE  
 ATEX 2014/34/EU  
 PED 2014/68/EU  
 SIL 3 CAPABLE

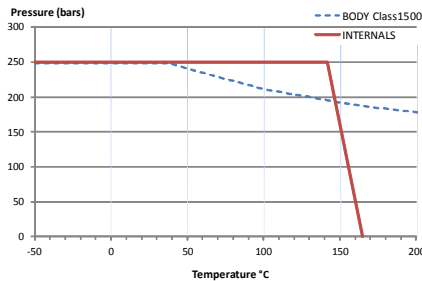

### PEKOS GROUP CERTIFICATES:



### DIMENSIONS & Technical information

DN	CL	D	L	E	A	B	C	F	H	G	V	X	Y	Z	n x d	ISO 5211	Torque	MAST	Weight
1/4"	1500	11,1	216	-	13,7	34	-	31	180	98	12	7,5	10	14	- x -	F03	14	17,0	4,0
3/8"	1500	11,1	216	-	17,1	34	-	31	180	98	12	7,5	10	14	- x -	F03	14	17,0	4,0
1/2"	1500	11,1	216	4,75	21,3	34	-	31	180	98	12	7,5	10	14	- x -	F03	14	17,0	4,0
3/4"	1500	15,5	229	5,54	26,7	37	-	41	180	108	12	7,5	11	12	- x -	F04	26	34,1	6,5
1"	1500	21	254	6,35	33,4	44	-	46	220	109	15	9	17	21	- x -	F05	37	64,7	8,0
1 1/4"	1500	34	280	6,35	42,2	60	-	63	250	139	22	16	26	33	- x -	F07	120	233,7	16,5
1 1/2"	1500	34	305	7,14	48,3	60	-	63	250	139	22	16	26	33	- x -	F07	120	233,7	17,0
2"	1500	43	368	8,71	60,3	70	-	64	250	140	22	16	20	30	- x -	F07	145	233,7	23,5

\*\* Depending on service conditions.

\* Dimensions are in mm.

\* Torque & MAST are in Nm

\* Weight is in Kilogram

\* Torque values have been measured  $\Delta P$  at maximum rating at room temperature

**DS-2318**  
 Rev.7