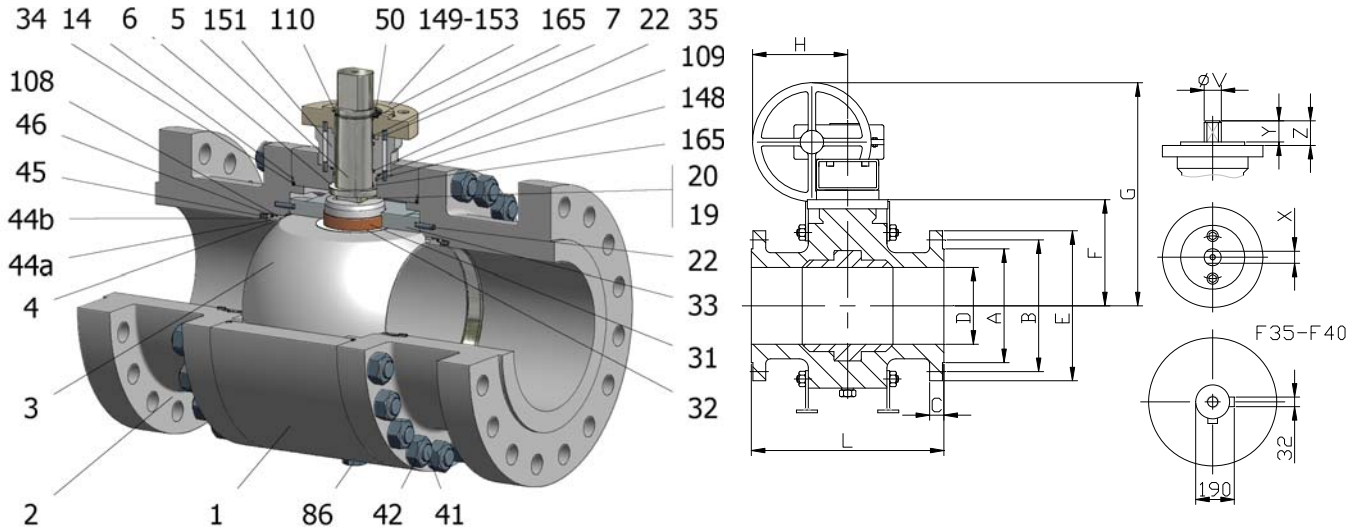

FIG.GKS 69 SGSGV CL600 4"-24" RF



Position	Description	Material
01	Body 1	C.S. A350 LF2
02	Body 2	C.S. A350 LF2
03	Ball	S.S. A351 CF8M
04	Seat	PTFE+CG
05	Stem	A182 F51
06	Stem seal	PEEK
07	Stem packing 1	Graphite
14	Body seal 1	PTFE+CG
19	Spring	Inconel X750
20	Antistatic ball	Inconel 625
22	Stop pin	S.S. AISI 316
31	Bearing	MU
32	Bearing disk	PTFE+FG
33	Support bearing	S275JR+ENP
34	Body seal 2	Graphite
35	O ring stem	FKM
41	Stud	A320 L7M
42	Nut	A194 7M
44a	Ring seat 1	S.S. AISI 316
44b	Ring seat 2	S.S. AISI 316
45	Spring	Inconel X750
46	Seat seal	Graphite
50	Subjection ring	S.S. AISI 420
86	Drain plug	C.S. A350 LF2
86a	Vent plug	C.S. A350 LF2
108	O ring seat	FKM
109	Cover seal	Graphite
110	Subjection ring seal	S.S. AISI 316 Nitrided
148	O ring cover	FKM
149	ISO cover	C.S. A350 LF2
151	Body cover 1	C.S. A350 LF2
152	Body cover bolt	S.S. (316)
153	ISO cover bolt	S.S. (316)
165	Stem bearing	PTFE+FG

General features

Full trunnion.
Three pieces.
Full bore.
Soft seat.
Bidirectional.
Spring loaded seat system.
Anti Blow out proof stem.
Anti static device.
Self-cavity pressure relief.
Double Block and Bleed.

Standards

Top flange ISO 5211
Flanges ANSI B16.5
Face to face ANSI B16.10
Testing API 598, API 6D, BS 6755-1
Design API 6D, B16.34
Materials according to NACE MR0175

Official approvals

CERTIFICATE FIRE SAFE
TA-LUFT VDI 2440
ISO 15848-1
ATEX 2014/34/EU
API 6D.
PED 2014/68/EU
SIL 3 CAPABLE

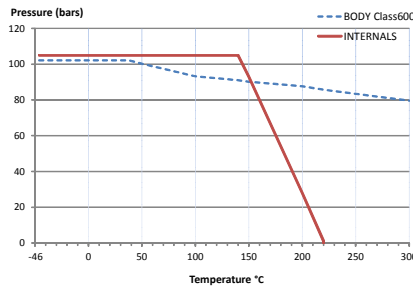

PEKOS GROUP CERTIFICATES:
ISO 9001-2008 / 2014/68/EU / API-6D



DIMENSIONS & Technical information

DN	CL	D	L	E	A	B	C	F	H	G	V	X	Y	Z	n x d	ISO 5211	Torque	MAST	Weight
4"	600	100	432	275	157	216	45	175	336	547	36	27	35	50	8 x 25	F12	715	2356,2	108
6"	600	150	559	355	216	292	55	229	436	607	48	36	40	63	12 x 29	F14	1580	5585,0	232
8"	600	201	660	420	270	349	63	295	461	600	48	36	40	63	12 x 32	F16-1	2500	5585,0	415
10"	600	252	787	510	324	432	71	330	461	635	48	36	40	63	16 x 35	F16-1	3161	5585,0	659
12"	600	303	838	560	381	489	74	400	461	705	72	55	70	83	20 x 35	F25	3770	19102,7	880
14"	600	334	889	605	413	527	78	426	563	785	72	55	70	83	20 x 38	F25	6420	19102,7	1400
16"	600	385	991	685	470	603	84	465	578	824	72	55	70	83	20 x 41	F25	8600	19102,7	1696
18"	600	436	1092	745	533	654	90	511	781	946	98	75	100	106	20 x 45	F30	13120	48235,0	2994
20"	600	487	1194	815	584	724	95	545	**	**	98	75	100	106	24 x 45	F30	17800	48235,0	3475
22"	600	538	1295	870	641	778	101	596	**	**	120	32	67	220	24 x 48	F35	23760	32400,0	4680
24"	600	589	1397	940	692	838	108	622	**	**	120	32	67	220	24 x 51	F35	26500	32400,0	5200

DS-291
Rev.7