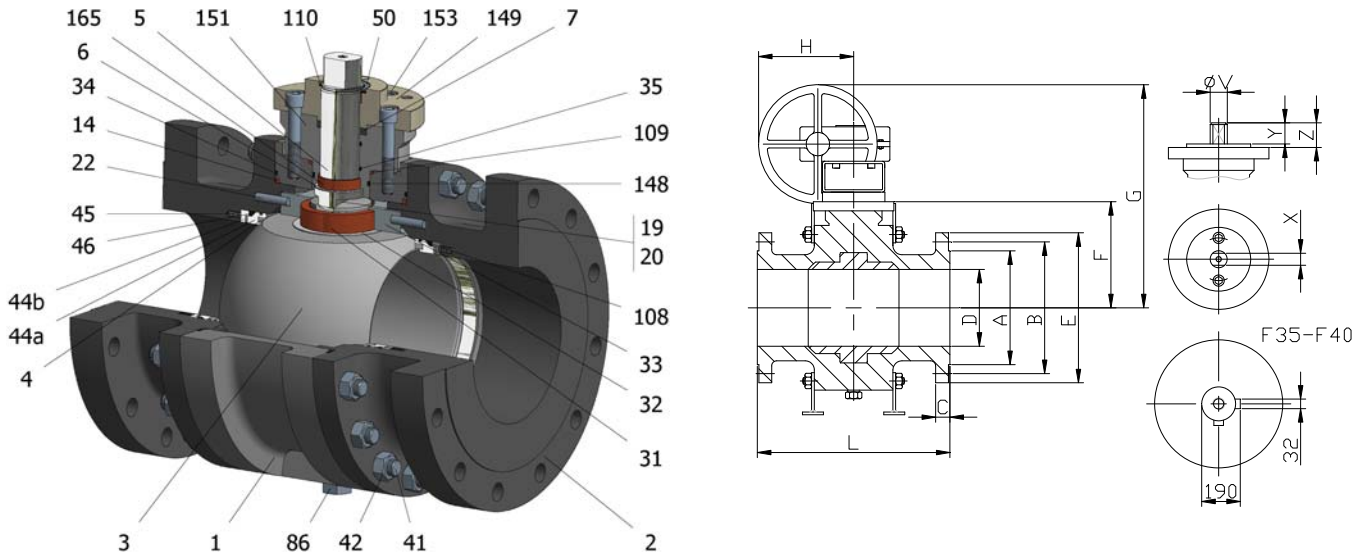

FIG.GKS 39 SGSGV CL300 4"-24"



Position	Description	Material
01	Body 1	C.S. A350 LF2
02	Body 2	C.S. A350 LF2
03	Ball	S.S. A351 CF8M
04	Seat	PTFE+CG
05	Stem	A182 F51
06	Stem seal	PTFE+CG
07	Stem packing 1	Graphite
14	Body seal 1	PTFE+CG
19	Spring	Inconel X750
20	Antistatic ball	Inconel 625
22	Stop pin	S.S. AISI 316
31	Bearing	MU
32	Bearing disk	PTFE+FG
33	Support bearing	S275JR+ENP
34	Body seal 2	Graphite
35	O ring stem	FKM
41	Stud	A320 L7M
42	Nut	A194 7M
44a	Ring seat 1	S.S. AISI 316
44b	Ring seat 2	S.S. AISI 316
45	Spring	Inconel X750
46	Seat seal	Graphite
50	Subjection ring	S.S. AISI 420
86	Drain plug	C.S. A350 LF2
86a	Vent plug	C.S. A350 LF2
108	O ring seat	FKM
109	Cover seal	Graphite
110	Subjection ring seal	S.S. AISI 316 Nitrided
148	O ring cover	FKM
149	ISO cover	C.S. A350 LF2
151	Body cover 1	C.S. A350 LF2
152	Body cover bolt	S.S. (316)
153	ISO cover bolt	S.S. (316)
165	Stem bearing	PTFE+FG

General features

Full trunnion.
Three pieces.
Full bore.
Soft seat.
Bidirectional.
Spring loaded seat system.
Anti Blow out proof stem.
Anti static device.
Self-cavity pressure relief.
Double Block and Bleed.

Standards

Top flange ISO 5211
Flanges ANSI B16.5
Face to face ANSI B16.10
Testing API 598, API 6D, BS 6755-1
Design API 6D, B16.34
Materials according to NACE MR0175

Official approvals

CERTIFICATE FIRE SAFE
TA-LUFT VDI 2440
ISO 15848-1
ATEX 2014/34/EU
API 6D.
PED 2014/68/EU
SIL 3 CAPABLE

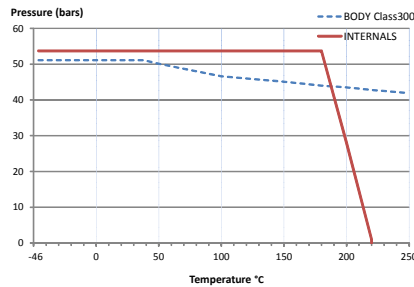

PEKOS GROUP CERTIFICATES:
ISO 9001-2008 / 2014/68/EU / API-6D



DIMENSIONS & Technical information

DN	CL	D	L	E	A	B	C	F	H	G	V	X	Y	Z	n x d	ISO 5211	Torque	MAST	Weight
4"	300	100	305	255	157	200	33	147	271	468	28	22	22	40	8 x 22	F10	490	1146,9	76,5
6"	300	150	403	320	216	270	38	210	336	582	36	27	35	50	12 x 22	F12	990	2356,2	138
8"	300	201	502	380	270	330	43	265	436	643	48	36	40	63	12 x 25	F14	1550	5585,0	239
10"	300	252	568	445	324	387	49	301	436	679	48	36	40	63	16 x 29	F14	2020	5585,0	437
12"	300	303	648	520	381	451	52	374	461	679	60	46	60	73	16 x 32	F16	2450	11084,1	729
14"	300	334	762	585	413	514	57	393	461	698	60	46	60	73	20 x 32	F16	4165	11084,1	928
16"	300	385	838	650	470	572	60	433	563	792	60	46	60	73	20 x 35	F16	5500	11084,1	1200
18"	300	436	914	710	533	629	62	500	563	859	72	55	70	83	24 x 35	F25	8100	19102,7	1550
20"	300	487	991	775	584	686	64	534	578	893	72	55	70	83	24 x 35	F25	10800	19102,7	2200
24"	300	589	1143	915	692	813	70	667	606	1103	120	32	67	200	24 x 41	F35	17760	32400,0	3730

DS-483
Rev.10