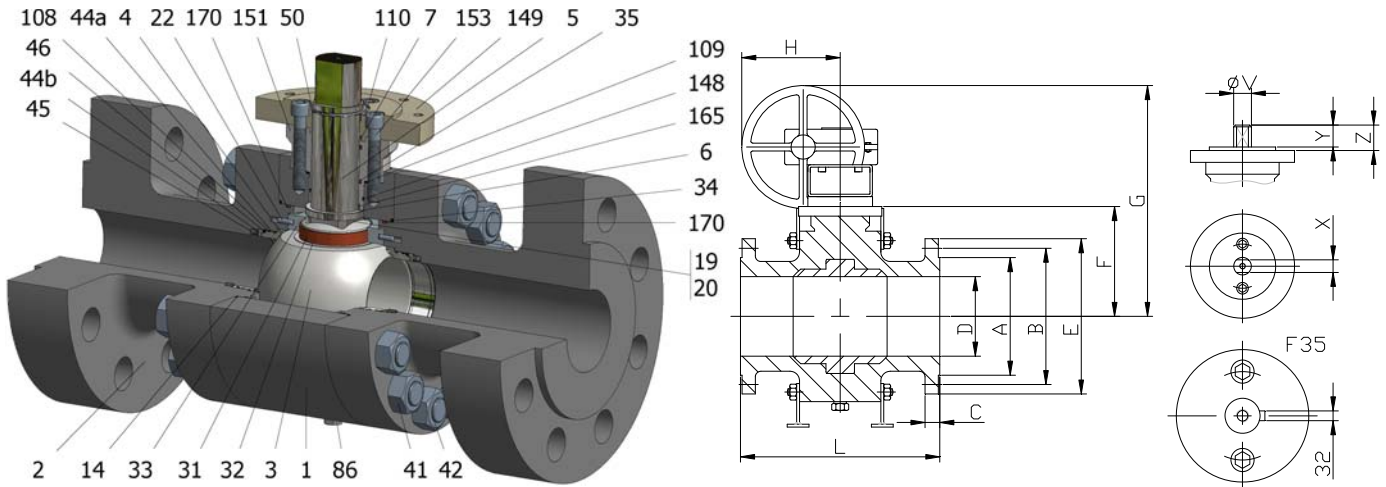

**FIG.GKS 256 PGGVV CL2500 2 1/2"-12"**



Position	Description	Material
01	Body 1	A182 F316
02	Body 2	A182 F316
03	Ball	A182 F51
04	Seat	PEEK
05	Stem	A182 F51
06	Stem seal	PEEK
07	Stem packing 1	Graphite
14	Body seal 1	Graphite
19	Spring	Inconel X750
20	Antistatic ball	Inconel 625
22	Stop pin	S.S. AISI 316
31	Bearing	MU-316
32	Bearing disk	PTFE+FG
33	Support bearing	A182 F51
34	Body seal 2	FKM
35	O ring stem	FKM
41	Stud	A193 B8M
42	Nut	A194 8M
44a	Ring seat 1	A182 F51
44b	Ring seat 2	A182 F51
45	Spring seat	Inconel X750
46	Seat seal	Graphite
50	Subjection ring	S.S. AISI 420
86	Drain plug	S.S. AISI 316
86a	Vent plug	S.S. AISI 316
108	O ring seat	FKM
109	Cover seal	Graphite
110	Subjection ring seal	S.S. AISI 316 Nitrided
148	O ring cover	FKM
149	ISO cover	S.S. AISI 316
151	Body cover 1	S.S. AISI 316
153	ISO cover bolt	S.S. (316)
165	Stem bearing	PTFE+FG
170	O stop seal	PTFE+CG

**General features**

Full trunnion.  
Three pieces.  
Full bore.  
Soft seat.  
Bidirectional.  
Spring loaded seat system.  
Anti Blow out proof stem.  
Anti static device.  
Self-cavity pressure relief.  
Double Block and Bleed.

**Standards**

Top flange ISO 5211  
Flanges ANSI B16.5  
Face to face ANSI B16.10  
Design API 6D, B16.34  
Testing API 598, API 6D, BS 6755-1  
Materials according to NACE MR0175

**Official approvals**

SIL 3 CAPABLE  
CERTIFICATE FIRE SAFE  
API 6D.  
ATEX 2014/34/EU  
PED 2014/68/EU

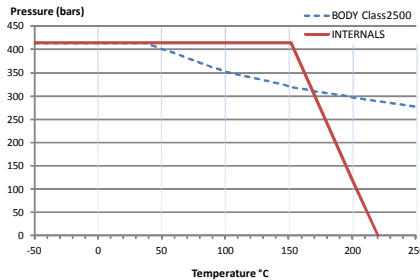

**PEKOS GROUP CERTIFICATES:**  
ISO 9001-2008 / 2014/68/EU / API-6D



**DIMENSIONS & Technical information**

DN	CL	D	L	E	A	B	C	F	H	G	V	X	Y	Z	n x d	ISO 5211	Torque	MAST	Weight
2 1/2"	2500	52	508	265	105	197	64	179	336	551	36	27	35	50	8 x 32	F12	1112	2356,2	154
3"	2500	62	578	305	127	229	74	184	355	562	36	27	35	44	8 x 35	F14-1	1654	2356,2	208
4"	2500	87	673	355	157	273	83	225	380	530	48	36	40	63	8 x 41	F16-1	2528	5585,0	340
6"	2500	131	914	485	216	368	114	308	440	670	72	55	70	83	8 x 54	F25	6443	19102,7	712
8"	2500	179	1022	550	270	438	133	328	482	687	72	55	70	83	12 x 54	F25	10035	19102,7	1859
10"	2500	223	1270	675	324	540	171	405	509	790	98	75	100	106	12 x 67	F30	12539	48235,0	2817
12"	2500	265	1422	762	381	619	191	471	509	856	120	32	67	200	12 x 73	F35	14690	32400,0	3892

\*\* Depending on service conditions. \* Dimensions are in mm. \* Torque & MAST are in Nm \* Weight is in Kilogram  
\* Torque values have been measured ΔP at maximum rating at room temperature

**DS-3933**  
Rev.2