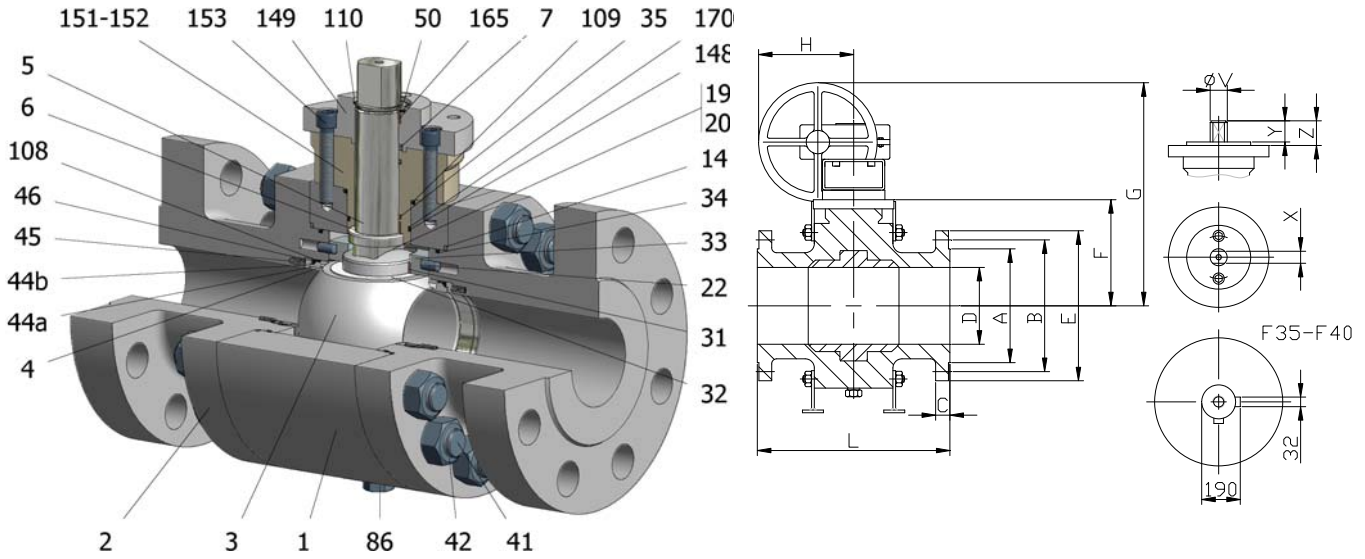

FIG.GKS 24 NGGVV PN250 DN50-300 F2



Position	Description	Material
01	Body 1	C.S. 1.0352
02	Body 2	C.S. 1.0352
03	Ball	D.S.S. 1.4462
04	Seat	DEVLON V
05	Stem	D.S.S. 1.4462
06	Stem seal	PEEK
07	Stem packing 1	Graphite
14	Body seal 1	Graphite
19	Spring	S.S. 1.4401
20	Antistatic ball	S.S. 1.4401
22	Stop pin	S.S. 1.4401
31	Bearing	MU
32	Bearing disk	PTFE+FG
33	Support bearing	S275JR+ENP
34	Body seal 2	FKM
35	O ring stem	FKM
41	Stud	A2-70
42	Nut	A2-70
44a	Ring seat 1	S.S. 1.4401
44b	Ring seat 2	S.S. 1.4401
45	Spring seat	Inconel X750
46	Seat seal	Graphite
50	Subjection ring	S.S. 1.4301
86	Drain plug	C.S. A350 LF2
86a	Vent plug	C.S. A350 LF2
108	O ring seat	FKM
109	Cover seal	Graphite
110	Subjection ring seal	S.S. 1.4401 Nitrided
148	O ring cover	FKM
149	ISO cover	C.S. 1.0460
151	Body cover 1	C.S. 1.0460
152	Body cover bolt	A4-70
153	ISO cover bolt	A4-70
165	Stem bearing	PTFE+FG
170	O stop seal	PTFE+CG

General features

- Full trunnion.
- Three pieces.
- Full bore.
- Soft seat.
- Bidirectional.
- Self-cavity pressure relief.
- Spring loaded seat system.
- Anti Blow out proof stem.
- Anti static device.
- Double Block and Bleed.

Standards

- Top flange ISO 5211
- Flanges EN 1092-01
- Face to face EN 558
- Design EN-12516, ISO 17292
- Testing EN-12266, ISO 5208

Official approvals

- CERTIFICATE FIRE SAFE
- ATEX 2014/34/EU
- PED 2014/68/EU
- SIL 3 CAPABLE

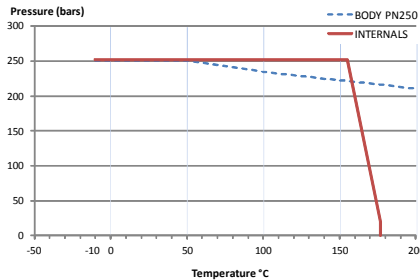

PEKOS GROUP CERTIFICATES:
ISO 9001-2008 / 2014/68/EU / API-6D



DIMENSIONS & Technical information

DN	PN	D	L	E	A	B	C	F	H	G	V	X	Y	Z	n x d	ISO 5211	Torque	MAST	Weight
50	250	50	300	200	102	150	38	127	200	385	36	27	35	50	8 x 26	F12	310	2356,2	46
65	250	65	340	230	122	180	42	135	200	393	36	27	35	50	8 x 26	F12	600	2356,2	76
80	250	80	380	255	138	200	46	175	271	496	36	27	35	44	8 x 30	F14-1	880	2356,2	102
100	250	100	430	300	162	235	54	200	336	582	48	36	40	63	8 x 33	F16-1	1365	5585,0	169
150	250	150	550	390	218	320	68	257	430	612	72	55	70	83	12 x 36	F25	3360	19102,7	360
200	250	200	650	485	285	400	82	333	430	688	72	55	70	83	12 x 42	F25	5230	19102,7	605
250	250	250	775	585	345	490	100	379	532	788	98	75	100	106	16 x 48	F30	6580	48235,0	895
300	250	300	900	690	-	590	120	442	532	851	120	32	--	200	16 x 52	F35	7740	48235,0	1230

** Depending on service conditions. * Dimensions are in mm. * Torque & MAST are in Nm. * Weight is in Kilogram
* Torque values have been measured ΔP at maximum rating at room temperature

DS-1893
Rev.2