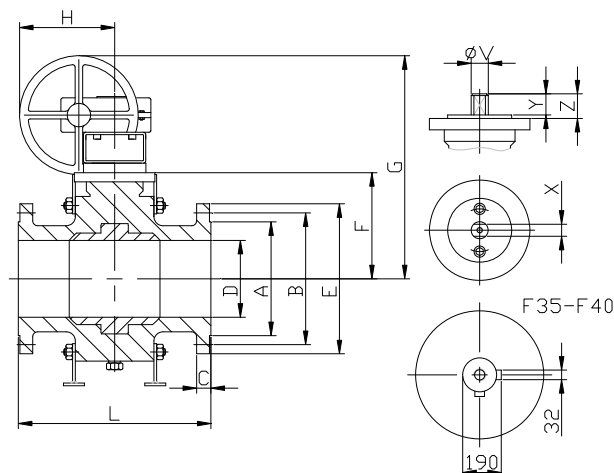
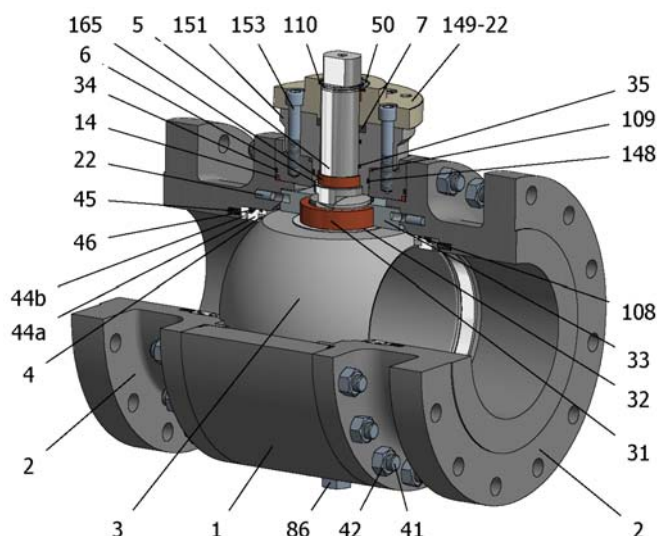

FIG.GKS 19 SGSGV CL150 6"-24"



Position	Description	Material
01	Body 1	C.S. A350 LF2
02	Body 2	C.S. A350 LF2
03	Ball	A182 F316
04	Seat	PTFE+CG
05	Stem	A182 F51
06	Stem seal	PTFE+CG
07	Stem packing 1	Graphite
14	Body seal 1	PTFE+CG
19	Spring	Inconel X750
20	Antistatic ball	Inconel 625
22	Stop pin	S.S. AISI 316
31	Bearing	MU
32	Bearing disk	PTFE+FG
33	Support bearing	S275JR+ENP
34	Body seal 2	Graphite
35	O ring stem	FKM
41	Stud	A320 L7M
42	Nut	A194 7M
44a	Ring seat 1	S.S. AISI 316
44b	Ring seat 2	S.S. AISI 316
45	Spring	Inconel X750
46	Seat seal	Graphite
50	Subjection ring	S.S. AISI 304
86	Drain plug	C.S. A350 LF2
86a	Vent plug	C.S. A350 LF2
108	O ring seat	FKM
109	Cover seal	Graphite
110	Subjection ring seal	S.S. AISI 316 Nitrided
148	O ring cover	FKM
149	ISO cover	C.S. A350 LF2
151	Body cover 1	C.S. A350 LF2
152	Body cover bolt	S.S. (316)
153	ISO cover bolt	S.S. (316)
165	Stem bearing	PTFE+FG

General features

- Full trunnion.
- Three pieces.
- Full bore.
- Soft seat.
- Bidirectional.
- Spring loaded seat system.
- Anti Blow out proof stem.
- Anti static device.
- Self-cavity pressure relief.
- Double Block and Bleed.

Standards

- Top flange ISO 5211
- Flanges ANSI B16.5
- Face to face ANSI B16.10
- Design AP 6D, B16.34
- Testing API 598, API 6D, BS 6755-1
- Materials according to NACE MR0175

Official approvals

- CERTIFICATE FIRE SAFE
- TA-LUFT VDI 2440
- ISO 15848-1
- API 6D.
- ATEX 2014/34/EU
- PED 2014/68/EU
- SIL 3 CAPABLE

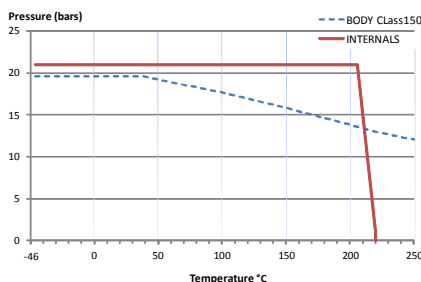

PEKOS GROUP CERTIFICATES:
ISO 9001-2008 / 2014/68/EU / API-6D

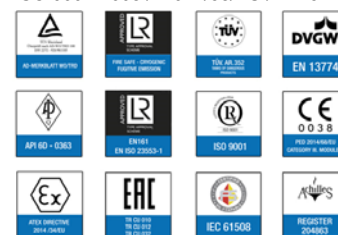

DIMENSIONS & Technical information

DN	CL	D	L	E	A	B	C	F	H	G	V	X	Y	Z	n x d	ISO 5211	Torque	MAST	Weight
6"	150	150	394	280	216	241	27	210	271	531	36	27	35	50	8 x 22	F12	640	2356,2	115
8"	150	201	457	345	270	299	30	265	336	647	48	36	40	63	8 x 22	F14	990	5585,0	200
10"	150	252	533	405	324	362	32	301	336	683	48	36	40	63	12 x 25	F14	1340	5585,0	385
12"	150	303	610	485	381	432	33	363	355	661	60	46	60	73	12 x 25	F16	1660	11084,1	515
14"	150	334	686	535	413	476	36	393	355	691	60	46	60	73	12 x 29	F16	2815	11084,1	690
16"	150	385	762	595	470	540	38	433	430	788	60	46	60	73	16 x 29	F16	3790	11084,1	1220
18"	150	436	864	635	527	578	41	500	480	905	72	55	70	83	16 x 32	F25	5100	19102,7	1700
20"	150	487	914	700	584	635	44	534	532	943	72	55	70	83	20 x 32	F25	6400	19102,7	2100
24"	150	589	1067	815	692	749	48	622	781	1057	98	75	100	106	20 x 35	F30	8200	48235,0	3550

** Depending on service conditions.

* Dimensions are in mm.

* Torque & MAST are in Nm

* Weight is in Kilogram

* Torque values have been measured ΔP at maximum rating at room temperature

DS-307
Rev.7