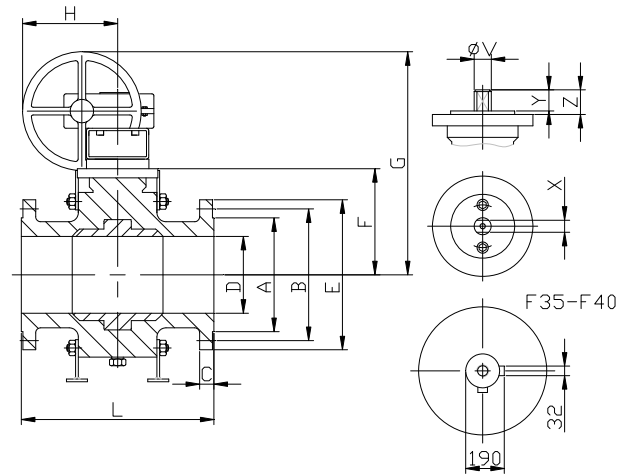
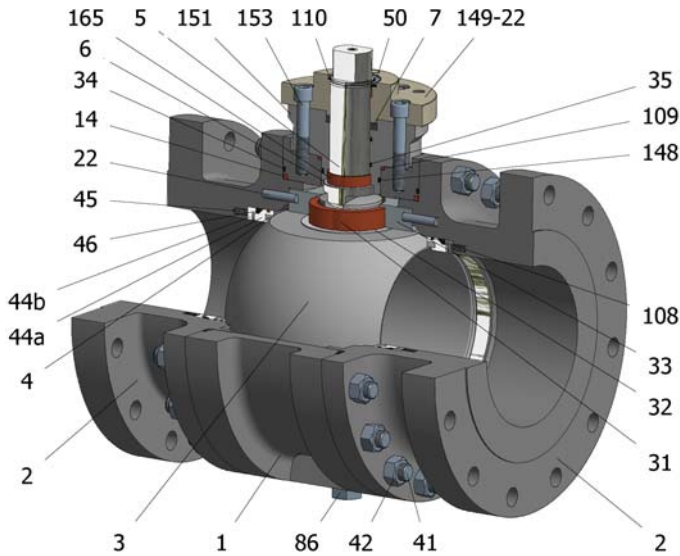

**FIG.GKS 16 SGSGV CL150 6"-24"**



Position	Description	Material
01	Body 1	A182 F316
02	Body 2	A182 F316
03	Ball	A182 F316
04	Seat	PTFE+CG
05	Stem	A182 F51
06	Stem seal	PTFE+CG
07	Stem packing 1	Graphite
14	Body seal 1	PTFE+CG
19	Spring	Inconel X750
20	Antistatic ball	Inconel 625
22	Stop pin	S.S. AISI 316
31	Bearing	MU-316
32	Bearing disk	PTFE+FG
33	Support bearing	S.S. AISI 316
34	Body seal 2	Graphite
35	O ring stem	FKM
41	Stud	A193 B8M
42	Nut	A194 8M
44a	Ring seat 1	S.S. AISI 316
44b	Ring seat 2	S.S. AISI 316
45	Spring	Inconel X750
46	Seat seal	Graphite
50	Subjection ring	S.S. AISI 420
86	Drain plug	S.S. AISI 316
86a	Vent plug	S.S. AISI 316
108	O ring seat	FKM
109	Cover seal	Graphite
110	Subjection ring seal	S.S. AISI 316 Nitrided
148	O ring cover	FKM
149	ISO cover	S.S. AISI 316
151	Body cover 1	S.S. AISI 316
152	Body cover bolt	S.S. (316)
153	ISO cover bolt	S.S. (316)
165	Stem bearing	PTFE+FG

**General features**

Full trunnion.  
Three pieces.  
Full bore.  
Soft seat.  
Bidirectional.  
Spring loaded seat system.  
Anti Blow out proof stem.  
Anti static device.  
Self-cavity pressure relief.  
Double Block and Bleed.

**Standards**

Top flange ISO 5211  
Flanges ANSI B16.5  
Face to face ANSI B16.10  
Testing API 598, API 6D, BS 6755-1  
Design API 6D, B16.34  
Materials according to NACE MR0175

**Official approvals**

CERTIFICATE FIRE SAFE  
TA-LUFT VDI 2440  
ISO 15848-1  
API 6D.  
ATEX 2014/34/EU  
PED 2014/68/EU  
SIL 3 CAPABLE

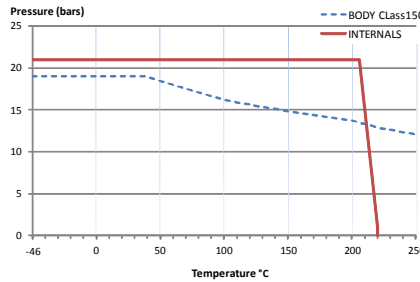

**PEKOS GROUP CERTIFICATES:**  
ISO 9001-2008 / 2014/68/EU / API-6D



**DIMENSIONS & Technical information**

DN	CL	D	L	E	A	B	C	F	H	G	V	X	Y	Z	n x d	ISO 5211	Torque	MAST	Weight
6"	150	150	394	280	216	241	27	210	271	531	36	27	35	50	8 x 22	F12	640	2356,2	115
8"	150	201	457	345	270	299	30	265	336	647	48	36	40	63	8 x 22	F14	990	5585,0	200
10"	150	252	533	405	324	362	32	301	336	683	48	36	40	63	12 x 25	F14	1340	5585,0	385
12"	150	303	610	485	381	432	33	363	355	661	60	46	60	73	12 x 25	F16	1660	11084,1	515
14"	150	334	686	535	413	476	36	393	355	691	60	46	60	73	12 x 29	F16	2815	11084,1	690
16"	150	385	762	595	470	540	38	433	430	788	60	46	60	73	16 x 29	F16	3790	11084,1	1220
18"	150	436	864	635	527	578	41	500	480	905	72	55	70	83	16 x 32	F25	5100	19102,7	1700
20"	150	487	914	700	584	635	44	534	532	943	72	55	70	83	20 x 32	F25	6400	19102,7	2100
24"	150	589	1067	815	692	749	48	622	781	1057	98	75	100	106	20 x 35	F30	8200	48235,0	3550

\*\* Depending on service conditions.

\* Dimensions are in mm.

\* Torque & MAST are in Nm

\* Weight is in Kilogram

\* Torque values have been measured ΔP at maximum rating at room temperature

**DS-2432**

Rev.3