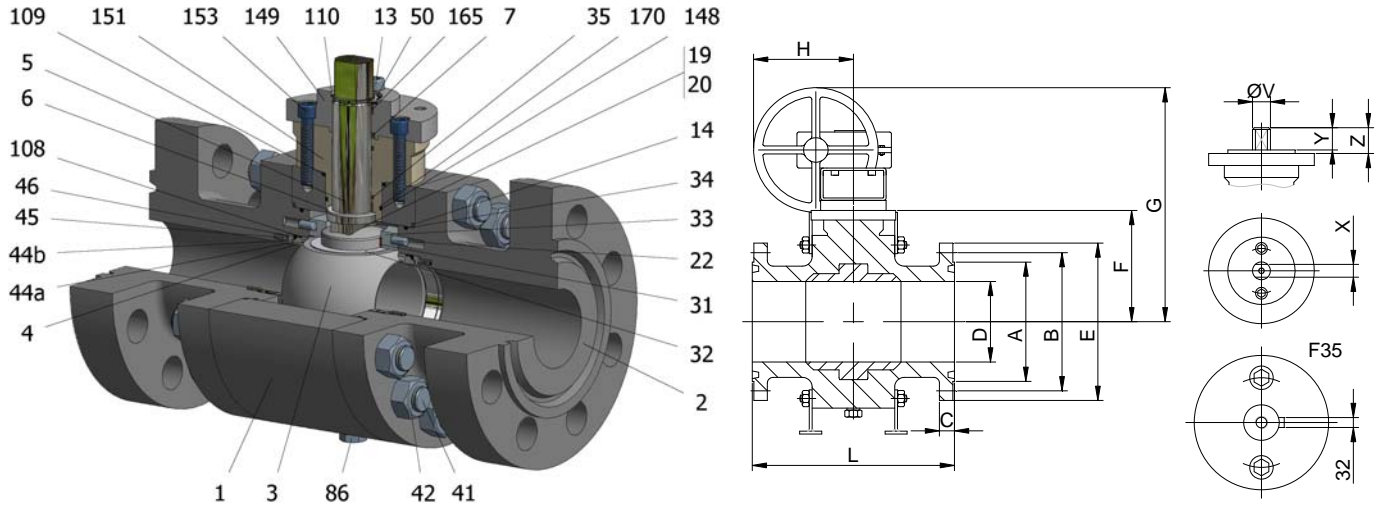

FIG.GKS 154 NGGVV CL1500 3"-16" RTJ



Position	Description	Material
01	Body 1	C.S. A-105
02	Body 2	C.S. A-105
03	Ball	A182 F51
04	Seat	DEVLON V
05	Stem	A182 F51
06	Stem seal	PEEK
07	Stem packing 1	Graphite
13	Cover bolt	S.S. (316)
14	Body seal 1	Graphite
19	Spring	Inconel X750
20	Antistatic ball	Inconel 625
22	Stop pin	S.S. AISI 316
31	Bearing	MU
32	Bearing disk	PTFE+FG
33	Support bearing	S275JR+ENP
34	Body seal 2	FKM
35	O ring stem	FKM
41	Stud	A320 L7M
42	Nut	A194 7M
44a	Ring seat 1	S.S. AISI 316
44b	Ring seat 2	S.S. AISI 316
45	Spring	Inconel X750
46	Seat seal	Graphite
50	Subjection ring	S.S. AISI 420
86	Drain plug	C.S. A350 LF2
86a	Vent plug	C.S. A350 LF2
108	O ring seat	FKM
109	Cover seal	Graphite
110	Subjection ring seal	S.S. AISI 316 Nitrided
148	O ring cover	FKM
149	ISO cover	C.S. A-105
151	Body cover 1	C.S. A-105
152	Body cover bolt	S.S. (316)
153	ISO cover bolt	S.S. (316)
165	Stem bearing	PTFE+FG
170	O stop seal	PTFE+CG

General features

Full trunnion.
Three pieces.
Full bore.
Soft seat.
Bidirectional.
Spring loaded seat system.
Anti Blow out proof stem.
Anti static device.
Self-cavity pressure relief.
Double Block and Bleed.

Standards

Top flange ISO 5211
Flanges ANSI B16.5
Face to face ANSI B16.10
Testing API 598, API 6D, BS 6755-1
Design API 6D, B16.34
Materials according to NACE MR0175

Official approvals

CERTIFICATE FIRE SAFE
ATEX 2014/34/EU
API 6D.
PED 2014/68/EU
SIL 3 CAPABLE

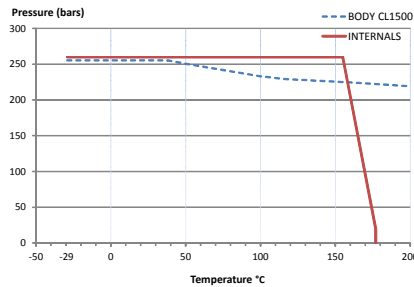

PEKOS GROUP CERTIFICATES:
ISO 9001-2008 / 2014/68/EU / API-6D



DIMENSIONS & Technical information

DN	CL	D	L	E	A	B	C	F	H	G	V	X	Y	Z	n x d	ISO 5211	Torque	MAST	Weight
3"	1500	75	473	265	168	203	57	175	271	496	36	27	35	50	8 x 32	F12	880	2356,2	110
4"	1500	100	549	310	194	241	63	190	336	572	36	27	35	44	8 x 35	F14-1	1365	2356,2	182
6"	1500	144	711	395	248	318	96	255	511	730	48	36	40	63	12 x 38	F16-1	3360	5585,0	390
8"	1500	192	842	485	318	394	98	333	511	868	72	55	70	83	12 x 45	F25	5230	19102,7	650
10"	1500	239	1001	585	371	483	119	368	613	957	72	55	70	83	12 x 51	F25	6580	19102,7	960
12"	1500	287	1146	675	438	572	138	400	613	1009	72	55	70	83	16 x 54	F25	7740	19102,7	1320
14"	1500	315	1276	750	489	635	156	400	628	1009	98	75	100	106	16 x 60	F30	13180	48235,0	1320
16"	1500	360	1406	825	546	705	152	465	**	**	120	32	67	200	16 x 67	F35	17500	32400	2360

** Depending on service conditions.

* Dimensions are in mm.

* Torque & MAST are in Nm

* Weight is in Kilogram

* Torque values have been measured ΔP at maximum rating at room temperature

DS-792
Rev.6