

## FIG.ZGKMS 24 CGGG PN100 DN100-350 F2

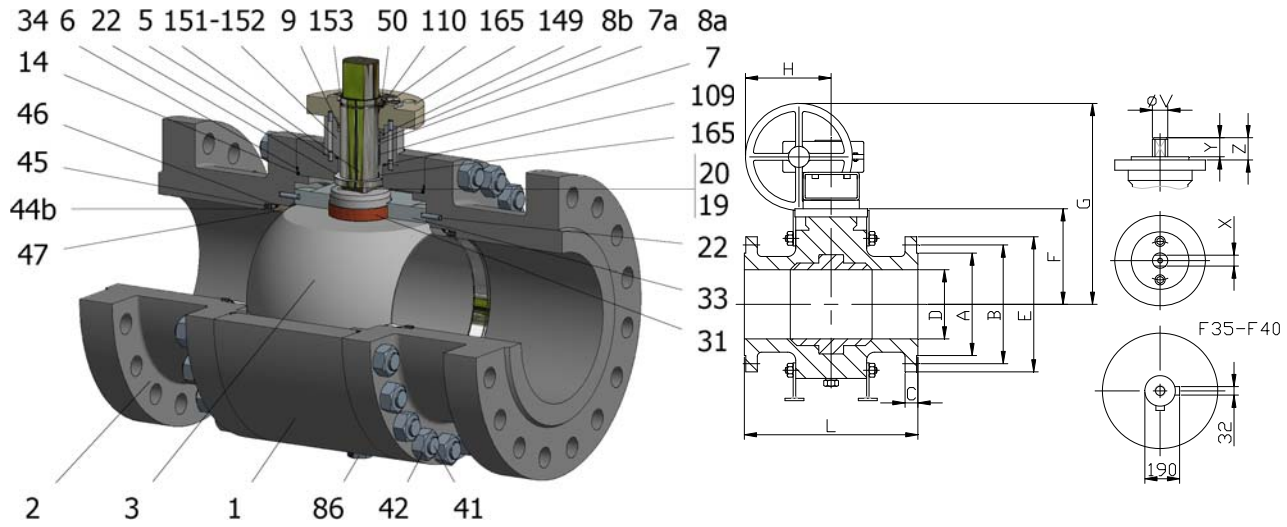

Position	Description	Material
01	Body 1	C.S. 1.0352
02	Body 2	C.S. 1.0352
03	Ball	S.S. 1.4401+Cr-Carbide
05	Stem	XM-19
06	Stem seal	S.S. 1.4401 Nitrided
07	Stem packing 1	Graphite
07a	Stem packing 2	Graphite
08a	Gland packing 1	S.S. 1.4401
08b	Gland packing 2	S.S. 1.4401
09	Spring washer	Inconel X718
14	Body seal 1	Graphite
19	Spring	S.S. 1.4401
20	Antistatic ball	S.S. 1.4401
22	Stop pin	S.S. 1.4401
31	Bearing	Carbongraphite
33	Support bearing	S275JR+ENP
34	Body seal 2	Graphite
41	Stud	A2-70
42	Nut	A2-70
44b	Ring seat 1	S.S. 1.4401
45	Spring	Inconel X750
46	Seat seal	Graphite
47	Metal seat	1.4401+Cr-Carbide
50	Subjection ring	S.S. 1.4301
86	Drain plug	C.S. A350 LF2
86a	Vent plug	C.S. A350 LF2
109	Cover seal	Graphite
110	Subjection ring seal	S.S. 1.4401 Nitrided
149	ISO cover	C.S. 1.0352
151	Body cover 1	C.S. 1.0352
152	ISO cover bolt	A4-70
153	ISO cover bolt	A4-70
165	Stem bearing	Carbongraphite

### General features

Full trunnion.  
Three pieces.  
Full bore.  
Metal to Metal.  
Bidirectional.  
Spring loaded seat system.  
Anti Blow out proof stem.  
Autoadjustable packing.  
Anti static device.  
Self-cavity pressure relief.  
Double Block and Bleed.

### Standards

Top flange ISO 5211  
Flanges EN 1092-01  
Face to face EN 558  
Testing EN-12266, ISO 5208  
Design EN-12516, ISO 17292

### Official approvals

CERTIFICATE FIRE SAFE  
TA-LUFT VDI 2440  
ISO 15848-1  
ATEX 2014/34/EU  
PED 2014/68/EU  
SIL 3 CAPABLE

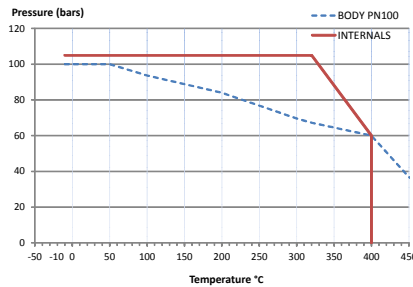

### PEKOS GROUP CERTIFICATES:



### DIMENSIONS & Technical information

DN	CL	D	L	E	A	B	C	F	H	G	V	X	Y	Z	n x d	ISO 5211	Torque	MAST	Weight
100	100	100	430	265	162	210	36	155	**	**	36	27	35	44	8 x 30	F14-1	1280	1989,7	103
125	100	125	500	315	188	250	40	191	**	**	36	27	35	44	8 x 33	F14-1	2065	1989,7	158
150	100	150	480	355	218	290	44	229	**	**	48	36	40	63	12 x 33	F16-1	2850	4716,3	212
200	100	200	600	430	285	360	52	295	**	**	60	46	60	73	12 x 36	F16	4445	9359,9	378
250	100	250	730	505	345	430	60	330	**	**	60	46	60	68	12 x 39	F25-1	5690	9359,9	632
300	100	300	850	585	410	500	68	400	**	**	72	55	70	83	16 x 42	F25	6800	16131,2	678
350	100	350	980	655	465	560	74	460	**	**	72	55	70	83	16 x 48	F30-1	11560	16131,2	1134

\*\* Depending on service conditions.

\* Dimensions are in mm.

\* Torque & MAST are in Nm

\* Weight is in Kilogram

\* Torque values have been measured  $\Delta P$  at maximum rating at room temperature

DS-2367

Rev.4