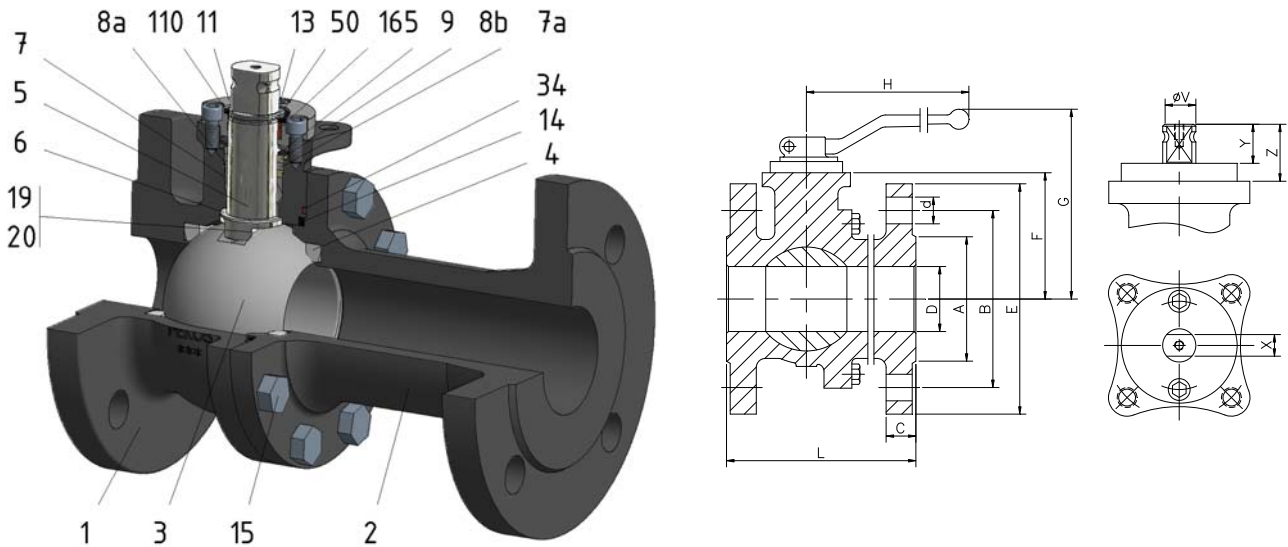

FIG.Z 29 TTTG PN40 DN15/125 F1



| Position | Description | Material |
|----------|----------------------|----------------------|
| 01 | Body 1 | C.S. 1.6220 |
| 02 | Body 2 | C.S. 1.6220 |
| 03 | Ball | S.S. 1.4408 |
| 04 | Seat | PTFE (modified) |
| 05 | Stem | S.S. 1.4401 |
| 06 | Stem seal | PTFE (modified)+FG |
| 07 | Stem packing 1 | PTFE (modified) |
| 07a | Stem packing 2 | Graphite |
| 08a | Gland packing 1 | S.S. 1.4401 |
| 08b | Gland packing 2 | S.S. 1.4401 |
| 09 | Spring washer | S.S. 1.4310 |
| 11 | Cover | S.S. 1.4408 |
| 13 | Cover bolt | A4-70 |
| 14 | Body seal 1 | PTFE (modified) |
| 15 | Body bolt | A2-70 |
| 16 | Handle | WCB |
| 17 | Handle bolt | 1.045(8.8) |
| 19 | Spring | S.S. 1.4401 |
| 20 | Antistatic ball | S.S. 1.4401 |
| 34 | Body seal 2 | Graphite |
| 50 | Subjection ring | S.S. 1.4021 |
| 110 | Subjection ring seal | S.S. 1.4401 Nitrided |
| 165 | Stem bearing | PTFE (modified)+FG |

General features

- Floating ball.
- Split body.
- Full bore.
- Soft seat.
- Bidirectional.
- Anti Blow out proof stem.
- Autoadjustable packing.
- Anti static device.
- Self-cavity pressure relief.

Standards

- Top flange ISO 5211
- Flanges EN 1092-01
- Face to face EN 558
- Testing EN-12266, ISO 5208
- Design EN-12516, ISO 17292

Official approvals

- CERTIFICATE FIRE SAFE
- TA-LUFT VDI 2440
- ISO 15848-1
- ATEX 2014/34/EU
- PED 2014/68/EU
- SIL 3 CAPABLE
- EN 161/EN ISO 23553-1

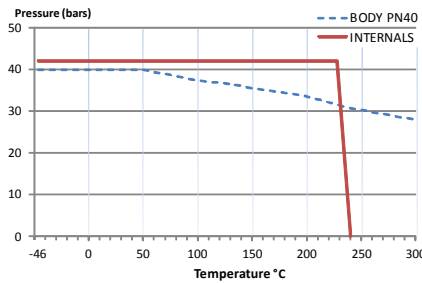

PEKOS GROUP CERTIFICATES:
ISO 9001-2008 / 2014/68/EU /API-6D



DIMENSIONS & Technical information

| DN | PN | D | L | E | A | B | C | F | H | G | V | X | Y | Z | n x d | ISO 5211 | Torque | MAST | Weight |
|-----|----|-----|-----|-----|-----|-----|----|-----|-----|-----|----|----|----|------|--------|----------|--------|--------|--------|
| 15 | 40 | 15 | 130 | 95 | 45 | 65 | 16 | 52 | 185 | 100 | 14 | 11 | 11 | 13,5 | 4 x 14 | F05 | 12 | 43,5 | 3,2 |
| 20 | 40 | 20 | 150 | 105 | 58 | 75 | 18 | 54 | 185 | 102 | 14 | 11 | 11 | 13,5 | 4 x 14 | F05 | 14 | 43,5 | 4,3 |
| 25 | 40 | 25 | 160 | 115 | 68 | 85 | 18 | 60 | 185 | 110 | 18 | 14 | 17 | 19,5 | 4 x 14 | F05 | 18 | 94,5 | 5,3 |
| 32 | 40 | 32 | 180 | 140 | 78 | 100 | 18 | 65 | 185 | 115 | 18 | 14 | 17 | 19,5 | 4 x 18 | F05 | 30 | 94,5 | 7,2 |
| 40 | 40 | 40 | 200 | 150 | 88 | 110 | 18 | 75 | 293 | 129 | 22 | 17 | 20 | 30 | 4 x 18 | F07 | 40 | 250,4 | 9,3 |
| 50 | 40 | 50 | 230 | 165 | 102 | 125 | 20 | 83 | 293 | 137 | 22 | 17 | 20 | 30 | 4 x 18 | F07 | 65 | 250,4 | 13,0 |
| 65 | 40 | 65 | 290 | 185 | 122 | 145 | 22 | 96 | 293 | 150 | 22 | 17 | 20 | 30 | 8 x 18 | F07 | 85 | 250,4 | 20,0 |
| 80 | 40 | 80 | 310 | 200 | 138 | 160 | 24 | 114 | 350 | 187 | 28 | 22 | 22 | 40 | 8 x 18 | F10 | 130 | 522,5 | 26,0 |
| 100 | 40 | 100 | 350 | 235 | 162 | 190 | 24 | 128 | 350 | 201 | 28 | 22 | 22 | 40 | 8 x 22 | F10 | 190 | 522,5 | 36,4 |
| 125 | 40 | 125 | 400 | 270 | 188 | 220 | 26 | 158 | 740 | 247 | 36 | 27 | 35 | 50 | 8 x 26 | F12 | 350 | 1073,4 | 73,0 |

** Depending on service conditions.

* Dimensions are in mm.

* Torque & MAST are in Nm.

* Weight is in Kilogram

* Torque values have been measured ΔP at maximum rating at room temperature

DS-2083

Rev.6