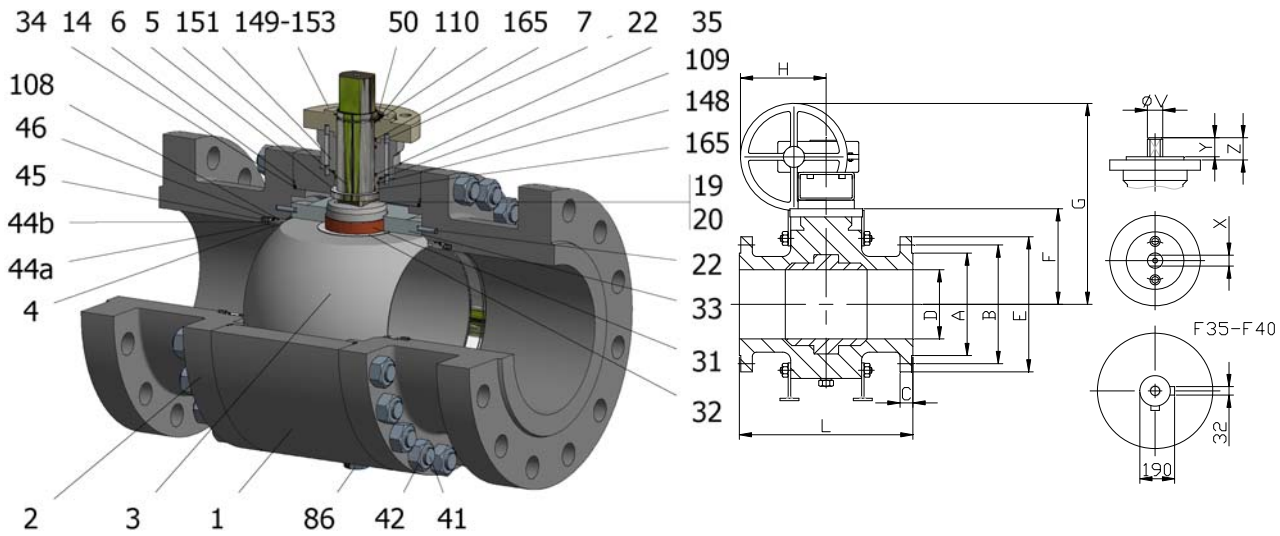

FIG.GKS 24 SGSGV PN63 DN100-400 F1



Position	Description	Material
01	Body 1	C.S. 1.0352
02	Body 2	C.S. 1.0352
03	Ball	S.S. 1.4401
04	Seat	PTFE (modified)+CG
05	Stem	D.S.S. 1.4462
06	Stem seal	PEEK
07	Stem packing 1	Graphite
14	Body seal 1	PTFE (modified)+CG
19	Spring	Inconel X750
20	Antistatic ball	Inconel 625
22	Stop pin	S.S. 1.4401
31	Bearing	MU
32	Bearing disk	PTFE (modified)+FG
33	Support bearing	S275JR+ENP
34	Body seal 2	Graphite
35	O ring stem	FKM
41	Stud	A2-70
42	Nut	A2-70
44a	Ring seat 1	S.S. 1.4401
44b	Ring seat 2	S.S. 1.4401
45	Spring	Inconel X750
46	Seat seal	Graphite
50	Subjection ring	S.S. 1.4301
86	Drain plug	C.S. A350 LF2
86a	Vent plug	C.S. A350 LF2
108	O ring seat	FKM
109	Cover seal	Graphite
110	Subjection ring seal	S.S. 1.4401 Nitrided
148	O ring cover	FKM
149	ISO cover	C.S. 1.0352
151	Body cover 1	C.S. 1.0352
152	Body cover bolt	A4-70
153	ISO cover bolt	A4-70
165	Stem bearing	PTFE (modified)+FG

General features

Full trunnion.
Three pieces.
Full bore.
Soft seat.
Bidirectional.
Spring loaded seat system.
Anti Blow out proof stem.
Autoadjustable packing.
Self-cavity pressure relief.
Double Block and Bleed.

Standards

Top flange ISO 5211
Flanges EN 1092-01
Face to face EN 558
Testing EN-12266, ISO 5208
Design EN-12516, ISO 17292

Official approvals

CERTIFICATE FIRE SAFE
TA-LUFT VDI 2440
ISO 15848-1
ATEX 2014/34/EU
PED 2014/68/EU
SIL 3 CAPABLE

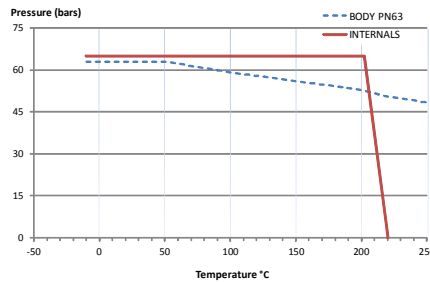

PEKOS GROUP CERTIFICATES:

ISO 9001-2008 / 2014/68/EU / API-6D



DIMENSIONS & Technical information

DN	PN	D	L	E	A	B	C	F	H	G	V	X	Y	Z	n x d	ISO 5211	Torque	MAST	Weight
100	63	100	350	250	162	200	30	175	336	547	36	27	35	50	8 x 26	F12	550	2356,2	87
125	63	125	400	295	188	240	34	210	336	582	48	36	40	63	8 x 30	F14	850	5585,0	128
150	63	150	480	345	218	280	36	229	436	607	48	36	40	63	8 x 33	F14	1150	5585,0	169
200	63	200	600	415	285	345	42	295	461	600	48	36	40	63	12 x 36	F16-1	1790	5585,0	298
250	63	250	730	470	345	400	46	330	461	635	48	36	40	63	12 x 36	F16-1	2320	5585,0	511
300	63	300	850	530	410	460	52	400	461	705	72	55	70	83	16 x 36	F25	2795	19102,7	779
350	63	350	980	600	465	525	56	426	563	785	72	55	70	83	16 x 39	F25	4750	19102,7	1085
400	63	400	1100	670	535	585	60	465	578	824	72	55	70	83	16 x 42	F25	6355	19102,7	1365

** Depending on service conditions.

* Dimensions are in mm.

* Torque & MAST are in Nm.

* Weight is in Kilogram

* Torque values have been measured ΔP at maximum rating at room temperature

DS-627
Rev.8