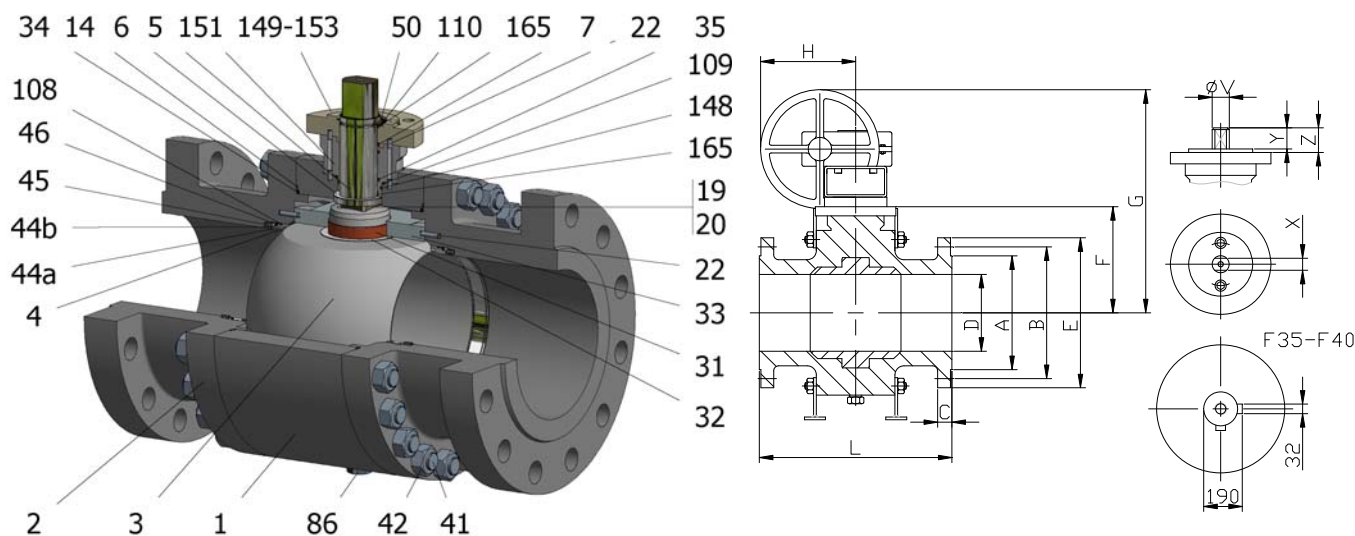

FIG.GKS 24 NGGVV PN160 DN80-300 F2



Position	Description	Material
01	Body 1	C.S. 1.0352
02	Body 2	C.S. 1.0352
03	Ball	S.S. 1.4401
04	Seat	DEVLON V
05	Stem	D.S.S. 1.4462
06	Stem seal	PEEK
07	Stem packing 1	Graphite
14	Body seal 1	Graphite
19	Spring	Inconel X750
20	Antistatic ball	Inconel 625
22	Stop pin	S.S. 1.4401
31	Bearing	MU
32	Bearing disk	PTFE (modified)+FG
33	Support bearing	S275JR+ENP
34	Body seal 2	FKM
35	O ring stem	FKM
41	Stud	A2-70
42	Nut	A2-70
44a	Ring seat 1	S.S. 1.4401
44b	Ring seat 2	S.S. 1.4401
45	Spring seat	Inconel X750
46	Seat seal	Graphite
50	Subjection ring	S.S. 1.4021
86	Drain plug	C.S. A350 LF2
86a	Vent plug	C.S. A350 LF2
109	Cover seal	Graphite
110	Subjection ring seal	S.S. 1.4401 Nitrided
149	ISO cover	C.S. 1.0352
151	Body cover 1	C.S. 1.0352
153	ISO cover bolt	A4-70
165	Stem bearing	PTFE (modified)+FG

General features

Full trunnion.
Three pieces.
Full bore.
Soft seat.
Bidirectional.
Spring loaded seat system.
Anti Blow out proof stem.
Self-cavity pressure relief.
Anti Blow out proof pin.
Double Block and Bleed.

Standards

Top flange ISO 5211
Flanges EN 1092-01
Face to face EN 558
Testing EN-12266, ISO 5208
Design EN-12516, ISO 17292

Official approvals

CERTIFICATE FIRE SAFE
TA-LUFT VDI 2440
ISO 15848-1
ATEX 2014/34/EU
PED 2014/68/EU
SIL 3 CAPABLE

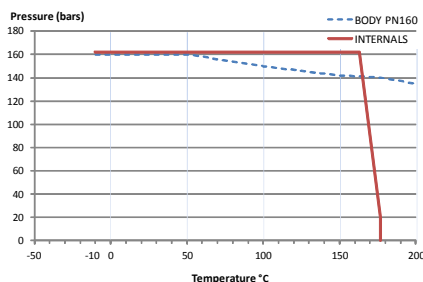

PEKOS GROUP CERTIFICATES:

ISO 9001-2008 / 2014/68/EU / API-6D



DIMENSIONS & Technical information

DN	PN	D	L	E	A	B	C	F	H	G	V	X	Y	Z	n x d	ISO 5211	Torque	MAST	Weight
80	160	75	380	230	138	180	36	160	271	481	36	27	35	50	8 x 26	F12	600	2356,2	98
100	160	100	430	265	162	210	40	175	336	547	36	27	35	50	8 x 30	F12	920	2356,2	153
150	160	150	550	355	218	290	50	229	380	614	48	36	40	63	12 x 33	F14	2175	5585,0	353
200	160	201	650	430	285	360	60	295	380	600	48	36	40	63	12 x 36	F16-1	3400	11084,1	595
250	160	252	775	515	345	430	68	330	380	635	48	36	40	63	12 x 42	F16-1	4300	11084,1	885
300	160	303	900	585	410	500	78	400	440	762	72	55	70	83	16 x 42	F25	5100	19102,7	1220

** Depending on service conditions.

* Dimensions are in mm.

* Torque & MAST are in Nm.

* Weight is in Kilogram

* Torque values have been measured ΔP at maximum rating at room temperature

DS-3916
Rev.3