

## FIG.ZFGOSU 36 KTTGN CL300 6"-12"

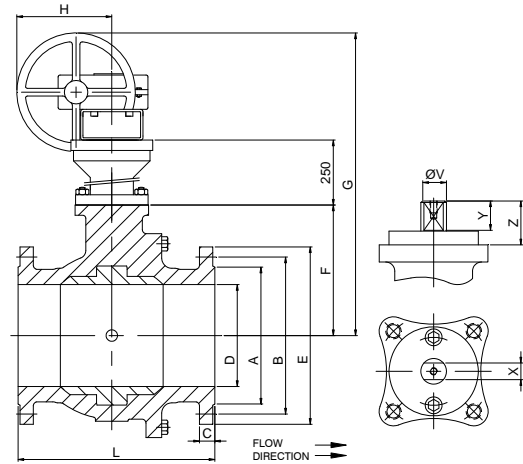
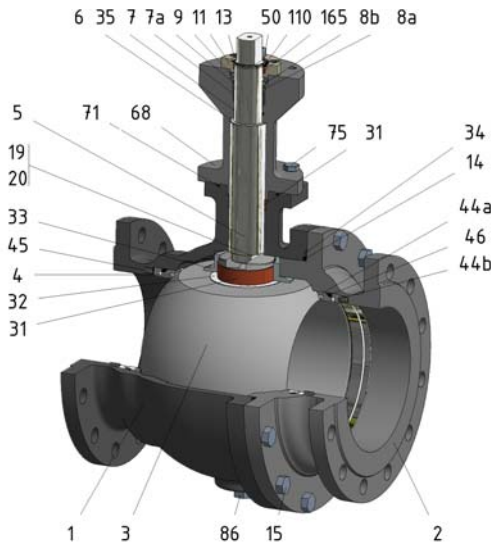

Position	Description	Material
01	Body 1	S.S. A351 CF8M
02	Body 2	S.S. A351 CF8M
03	Ball	S.S. A351 CF8M
04	Seat	PTFE
05	Stem	XM-19
06	Stem seal	PTFE
07	Stem packing 1	PTFE (modified)
07a	Stem packing 2	Graphite
08a	Gland packing 1	S.S. AISI 316
08b	Gland packing 2	S.S. AISI 316
09	Spring washer	S.S. AISI 301
11	Cover	S.S. A351 CF8M
13	Cover bolt	S.S. (316)
14	Body seal 1	PTFE (modified)
15	Body bolt	A320 B8M
19	Spring	S.S. AISI 316
20	Antistatic ball	S.S. AISI 316
31	Bearing	MU-316
32	Bearing disk	PTFE (modified)+FG
33	Support bearing	S.S. AISI 316
34	Body seal 2	Graphite
35	O ring stem	NBR
44a	Ring seat 1	S.S. AISI 316
44b	Ring seat 2	S.S. AISI 316
45	Spring seat	Inconel X750
46	Seat seal	Graphite
50	Subjection ring	S.S. AISI 420
68	Stem extension casing	S.S. AISI 316
71	Extension seal	Graphite
75	Extension bolt	S.S. (316)
86	Drain plug	S.S. AISI 316
86a	Vent plug	S.S. AISI 316
110	Subjection ring seal	S.S. AISI 316 Nitrided
165	Stem bearing	PTFE (modified)+FG

### General features

Full trunnion.  
Cryogenic.  
Split body.  
Full bore.  
Soft seat.  
Unidirectional.  
Spring loaded seat system.  
Anti Blow out proof stem.  
Autoadjustable packing.  
Anti static device.  
Self-cavity pressure relief.  
Degreased

### Standards

Top flange ISO 5211  
Flanges ANSI B16.5  
Face to face ANSI B16.10  
Design API 6D, B16.34  
Testing API 598, API 6D, BS 6755-1  
Materials according to NACE MR0175

### Official approvals

CERTIFICATE FIRE SAFE  
CRYOGENIC  
TA-LUFT VDI 2440  
ISO 15848-1  
API 6D.  
ATEX 2014/34/EU  
PED 2014/68/EU  
SIL 3 CAPABLE

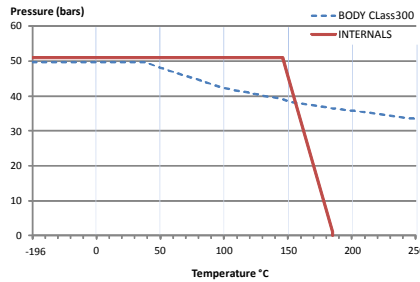

### PEKOS GROUP CERTIFICATES:



### DIMENSIONS & Technical information

DN	CL	D	L	E	A	B	C	F	H	G	V	X	Y	Z	n x d	ISO 5211	Torque	MAST	Weight
6"	300	150	403	320	216	270	38	176	336	848	36	27	35	50	12 x 22	F14-1	1650	1989,7	144
8"	300	200	502	380	270	330	43	245	355	933	48	36	40	63	12 x 25	F16-1	2580	4716,3	242
10"	300	250	568	445	324	387	49	285	430	1030	48	36	40	63	16 x 29	F16-1	2730	4716,3	349
12"	300	300	648	520	381	451	52	329	430	1074	48	36	40	63	16 x 32	F16-1	4080	4716,3	492

\*\* Depending on service conditions.

\* Dimensions are in mm.

\* Torque & MAST are in Nm

\* Weight is in Kilogram

\* Torque values have been measured ΔP at maximum rating at room temperature

DS-2607  
Rev.5