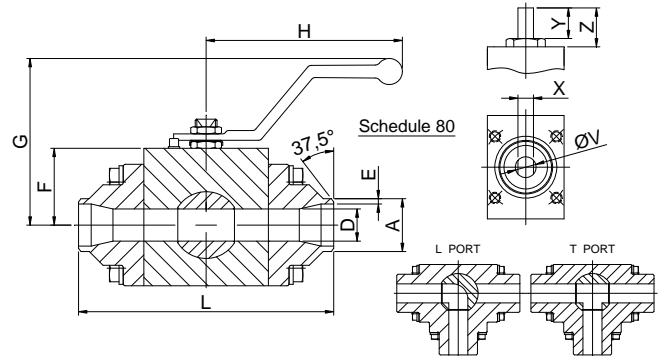
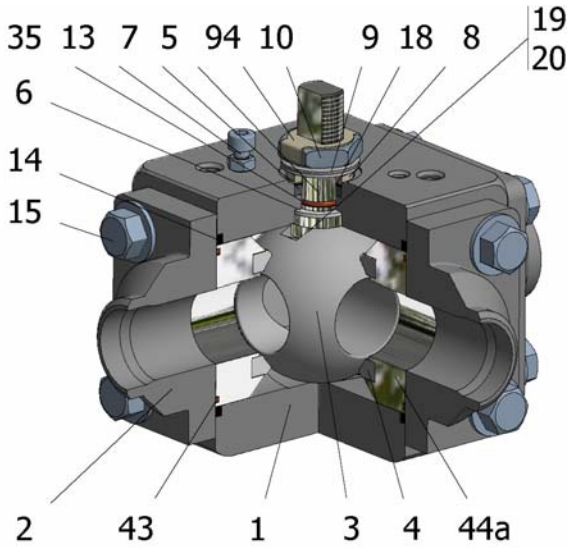

FIG.V 89 SGS-V CL600 1/2"-1" BW L/T



Position	Description	Material
01	Body 1	C.S. A350 LF2/A-105
02	Body 2	C.S. A350 LF2/A-105
03	Ball	A182 F316/316L
04	Seat	PTFE (modified)+CG
05	Stem	S.S. AISI 316/316L
06	Stem seal	PTFE (modified)+CG
07	Stem packing 1	Graphite
08	Gland packing 1	S.S. AISI 316
09	Spring washer	S.S. AISI 301
10	Stem nut	S.S. AISI 304
13	Cover bolt	S.S. (316)
14	Body seal 1	PTFE (modified)+CG
15	Body bolt	A320 L7M
16	Handle	C.S. PAINTING
18	Thrust washer	PTFE (modified)+CG
19	Spring	S.S. AISI 316
20	Antistatic ball	S.S. AISI 316
35	O ring stem	FKM
43	Seat seal	FKM
44a	Ring seat 1	S.S. AISI 316
94	Stop washer	S.S. AISI 301

General features

- Floating ball.
- Full bore.
- Soft seat.
- Three way.
- Fire Safe Design
- Anti Blow out proof stem.
- Autoadjustable packing.
- Anti static device.
- Self-cavity pressure relief.
- Allows in-line maintenance

Standards

- Top flange ISO 5211
- Buttwelding ends B16.25
- Materials according to NACE MR0175
- Design B16.34
- Testing API 598, BS 6755-1

Official approvals

- ATEX 2014/34/EU
- PED 2014/68/EU
- SIL 3 CAPABLE

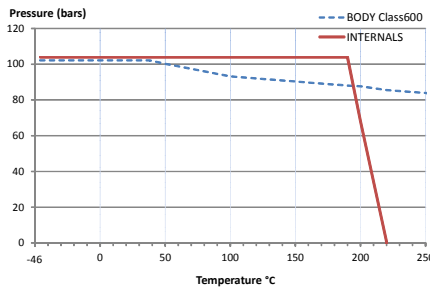

PEKOS GROUP CERTIFICATES:

ISO 9001-2008 / 2014/68/EU / API-6D



DIMENSIONS & Technical information

DN	CL	D	L	E	A	B	C	F	H	G	V	X	Y	Z	n x d	ISO 5211	Torque	MAST	Weight
1/2"	600	14,2	119	3,73	21,3	-	-	30	180	97	12	7,5	14	23	- x -	F04/-	16	34,1	3
3/4"	600	21	150	3,91	26,7	-	-	39,5	180	102	12	7,5	14	18,5	- x -	F04/F07	25	34,1	5
1"	600	25,5	158	4,55	33,4	-	-	42,5	220	114	15	9	18	28	- x -	F05/F07	36	64,6	7

** Depending on service conditions.

* Dimensions are in mm.

* Torque & MAST are in Nm

* Weight is in Kilogram

* Torque values have been measured ΔP at maximum rating at room temperature

DS-3801
Rev.5