

## FIG.K 809 SGSGV CL600 2"-2 1/2" NPT

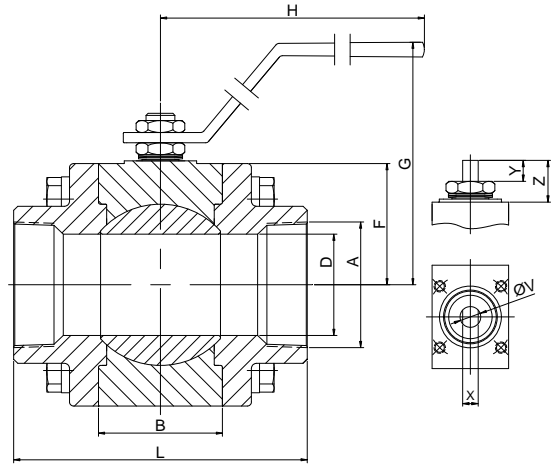
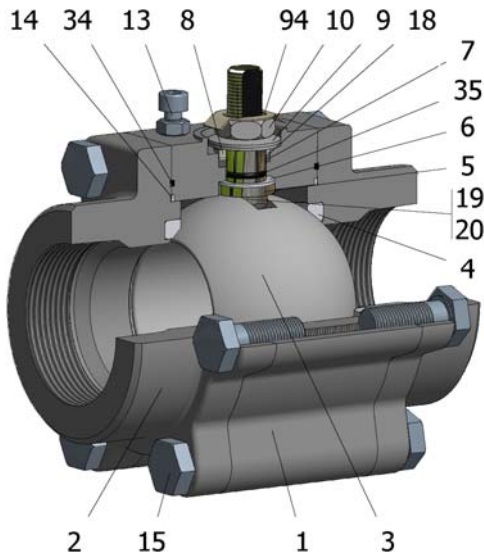

Position	Description	Material
01	Body 1	C.S. A350 LF2/A-105
02	Body 2	C.S. A350 LF2/A-105
03	Ball	A182 F316/316L
04	Seat	PTFE (modified)+CG
05	Stem	S.S. AISI 316/316L
06	Stem seal	PTFE (modified)+CG
07	Stem packing 1	Graphite
08	Gland packing	S.S. AISI 316
09	Spring washer	S.S. AISI 301
10	Stem nut	S.S. AISI 304
13	Stop bolt	S.S. (316)
14	Body seal 1	PTFE (modified)+CG
15	Body bolt	A320 L7M
16	Handle	PAINTED C.S.
18	Thrust washer	PTFE (modified)+CG
19	Spring	S.S. AISI 316
20	Antistatic ball	S.S. AISI 316
34	Body seal 2	Graphite
35	O ring stem	FKM
94	Stop washer	S.S. AISI 301

### General features

Floating ball.  
Three pieces.  
Full bore.  
Soft seat.  
Bidirectional.  
Anti Blow out proof stem.  
Autoadjustable packing.  
Anti static device.  
Self-cavity pressure relief.

### Standards

Top flange ISO 5211  
Threaded ends NPT  
Materials according to NACE MR0175  
Design B16.34  
Testing API 598, BS 6755-1

### Official approvals

CERTIFICATE FIRE SAFE  
ATEX 2014/34/EU  
PED 2014/68/EU  
SIL 3 CAPABLE

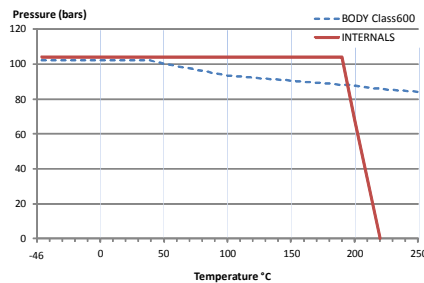

### PEKOS GROUP CERTIFICATES: ISO 9001-2008 / 2014/68/EU /API-6D



### DIMENSIONS & Technical information

DN	CL	D	L	E	A	B	C	F	H	G	V	X	Y	Z	n x d	ISO 5211	Torque	MAST	Weight
2"	600	49	142	-	2"	60	-	58	233	119	15	9	16	24	- x -	F05	-	64,7	10
2 1/2"	600	62	170	-	2 1/2"	72	-	70	425	143	22	16	22	31	- x -	F07	-	233,7	14

\*\* Depending on service conditions.

\* Dimensions are in mm.

\* Torque & MAST are in Nm

\* Weight is in Kilogram

\* Torque values have been measured  $\Delta P$  at maximum rating at room temperature

DS-324  
Rev.14